

Installation of the sprocket to the hub

Place right hand dust cap B onto the driver on the right side of the hub body. Next, install the sprocket and secure it in place with the snap ring.

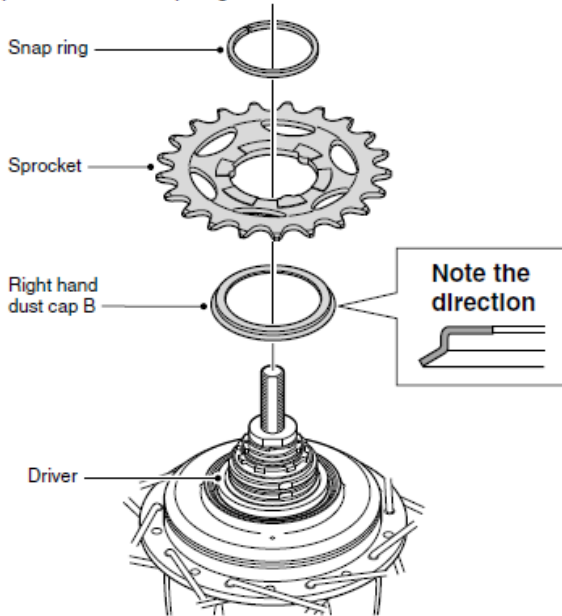

Note:

If the sprocket is a 16T thick tooth inward assembling sprocket or for belt drive specifications, right hand dust cap B cannot be installed and so it should not be used.

Installation of the cassette joint to the hub

1. Install the driver cap to the driver on the right side of the hub body.

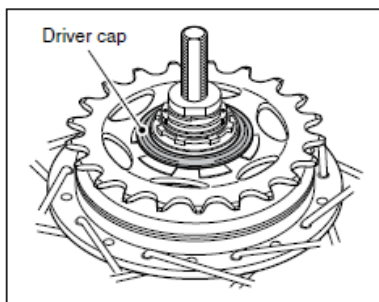
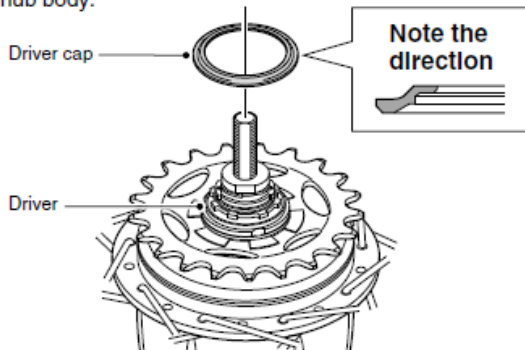

2. Turn the cassette joint pulley in the direction of the arrow in the illustration to align the red ● marks on the pulley and the bracket. With the cassette joint in this condition, install it so that the red ● mark on the cassette joint is aligned with the red ● mark on the right side of the hub body.

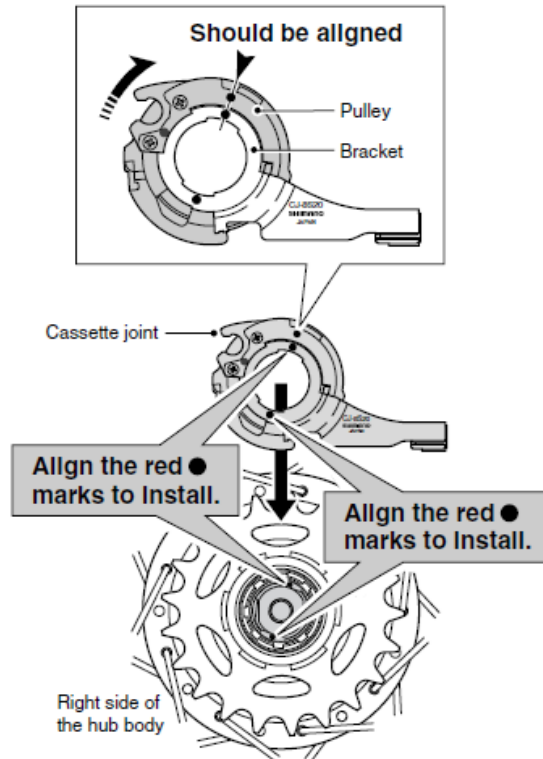

3. Secure the cassette joint to the hub with the cassette joint fixing ring. When installing the cassette joint fixing ring, align the yellow ● mark with the yellow ● mark on the cassette joint pulley, and then turn the cassette joint fixing ring 45° clockwise.

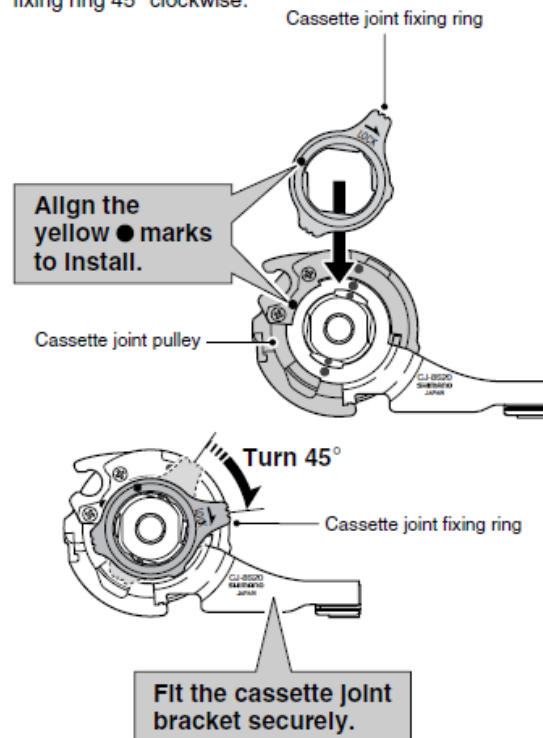

Installation of the hub to the frame

1. Mount the chain on the sprocket, and then set the hub axle into the dropouts.

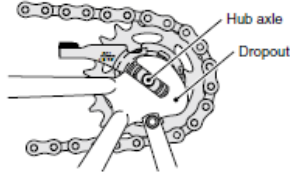

2. Place the non-turn washers onto the right side and left side of the hub axle. At this time, turn the cassette joint so that the projecting parts of the non-turn washers fit into the grooves of the dropouts. If this is done, the cassette joint can be installed so that it is almost parallel to the chainstay.

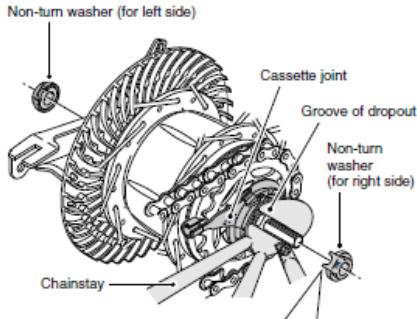

- Use whichever non-turn washers match the shape of the dropouts. Different non-turn washers are used at the left and right sides.

Dropouts	Non-turn washer		
	Mark/Color		Size
	Right	Left	
Standard	5R / Yellow	5L / Brown	$\theta \leq 20^\circ$
	7R / Black	7L / Gray	$\theta \leq 38^\circ$
Reversed	6R / Silver	6L / White	$\theta = 0^\circ$
Reversed (full chain case)	5R / Yellow	5L / Brown	$\theta = 0^\circ$
Vertical	8R / Blue	8L / Green	$\theta = 60^\circ - 90^\circ$



- The projecting parts should be on the dropouts side.
- Install the non-turn washers so that the projecting parts is securely in the dropouts grooves on either side of the hub axle.

3. Install the brake arm of the Inter-M brake to the chainstay with the brake arm clip, provisionally tighten the clip screw and clip nut, and then tighten the brake unit fixing nut.

Note:

If the brake arm is in the incorrect position as shown in the illustration so that it cannot be provisionally installed to the chainstay, loosen the brake unit fixing nut and turn the brake arm. Then, after provisionally securing the brake arm to the chainstay, tighten the brake unit fixing nut.

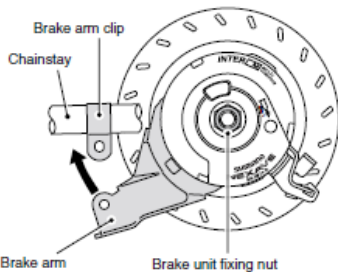

Tightening torque:
20 – 25 N·m {174 – 217 in. lbs.}

4. Take up the slack in the chain and secure the wheel to the frame with the cap nuts.

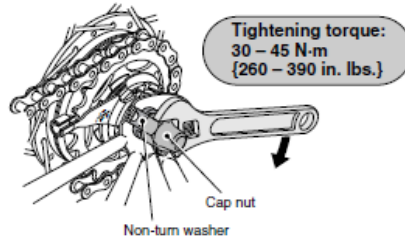

Note:

When installing a part such as a mudguard stay to the hub axle, install in the order shown in the illustration below.

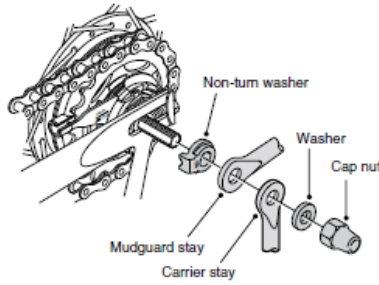

5. Fix the brake arm of the Inter-M brake securely to the chainstay with the brake arm clip.

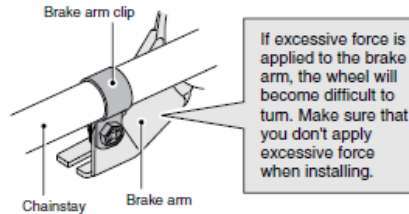

Note:

- When installing the brake arm clip, securely tighten the clip screw while holding the clip nut with a 10 mm spanner.

Tightening torque:
2 – 3 N·m {17 – 26 in. lbs.}

- After installing the brake arm clip, check that the clip screw protrudes about 2 – 3 mm from the surface of the clip nut.

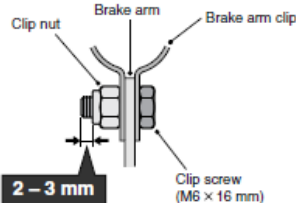

These service instructions explain how to use and maintain the Shimano bicycle parts which have been used on your new bicycle. For any questions regarding your bicycle or other matters which are not related to Shimano parts, please contact the place of purchase or the bicycle manufacturer.

These service instructions are printed on recycled paper.

Please note: Specifications are subject to change for improvement without notice. (English)

SHIMANO

SHIMANO AMERICAN CORPORATION

One Holland, Irvine, California 92618, U.S.A. Phone: +1-949-951-5003

SHIMANO EUROPE B.V.

Industrieweg 24, 8071 CT Nurspeet, The Netherlands Phone: +31-341-272222

SHIMANO INC.